

1 x ausführen

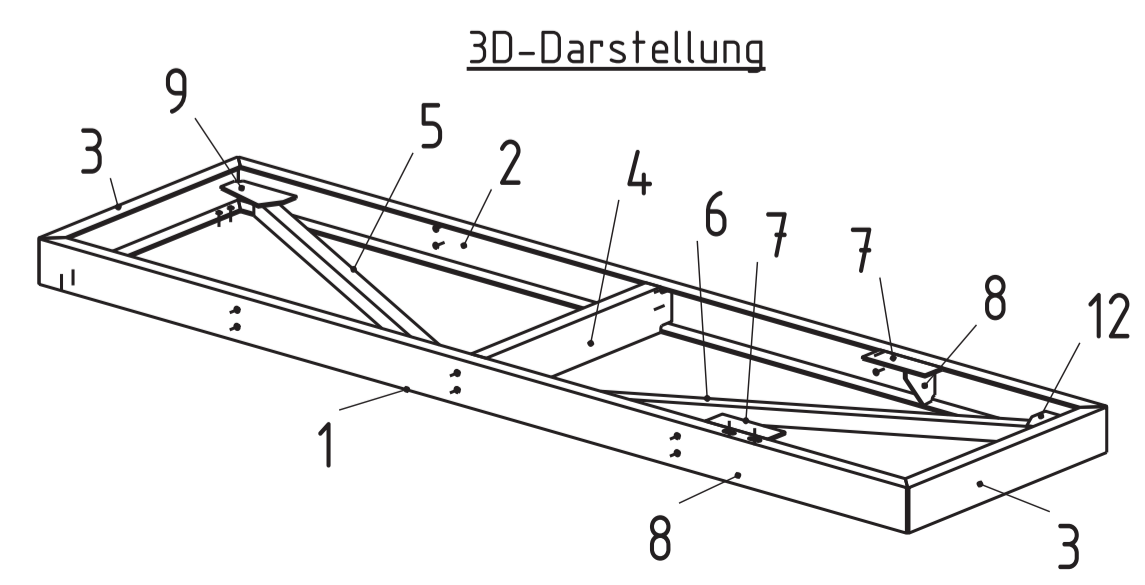
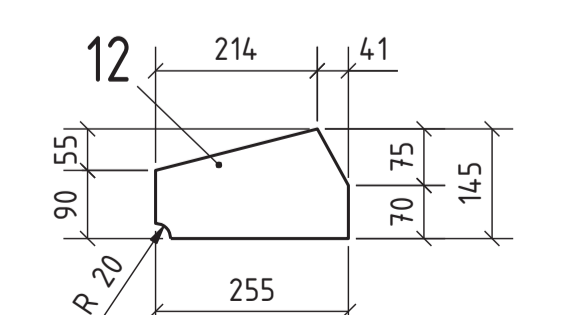
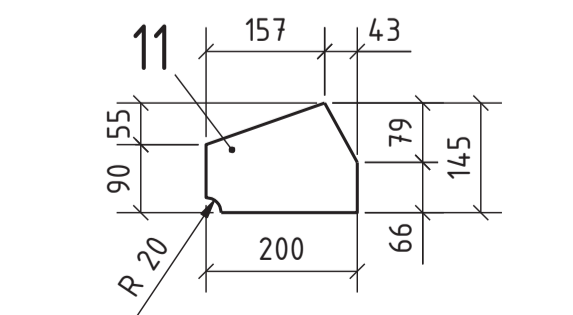
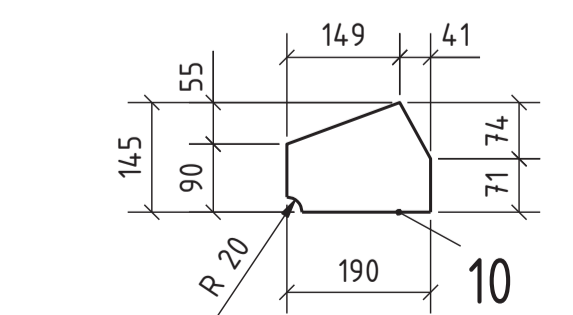
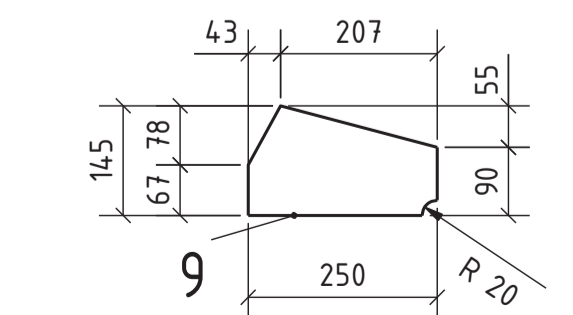
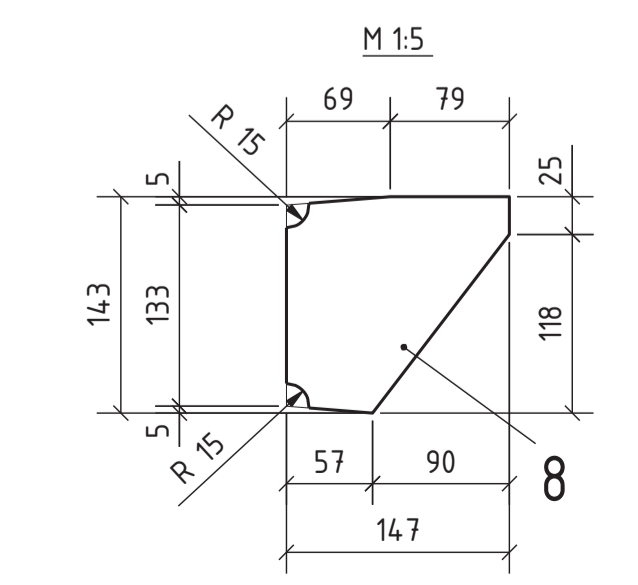
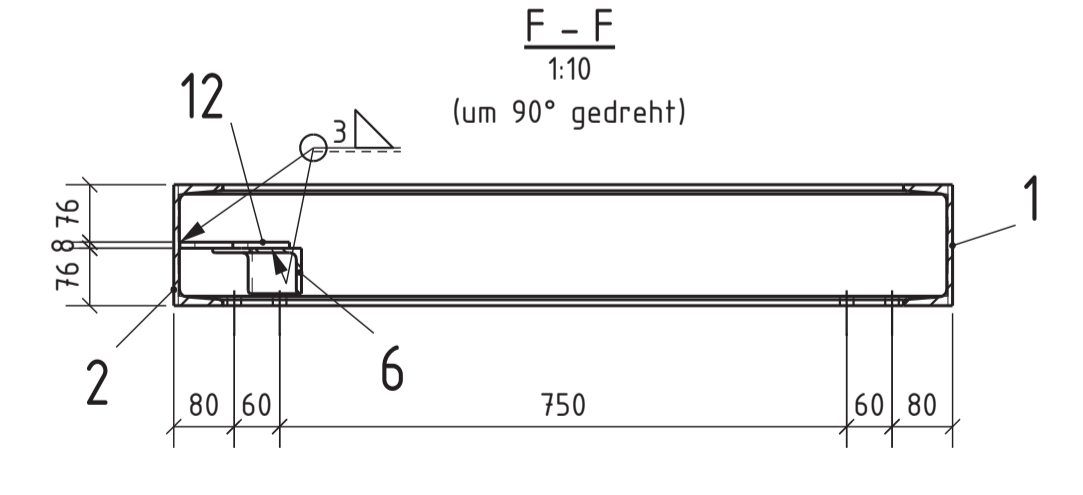
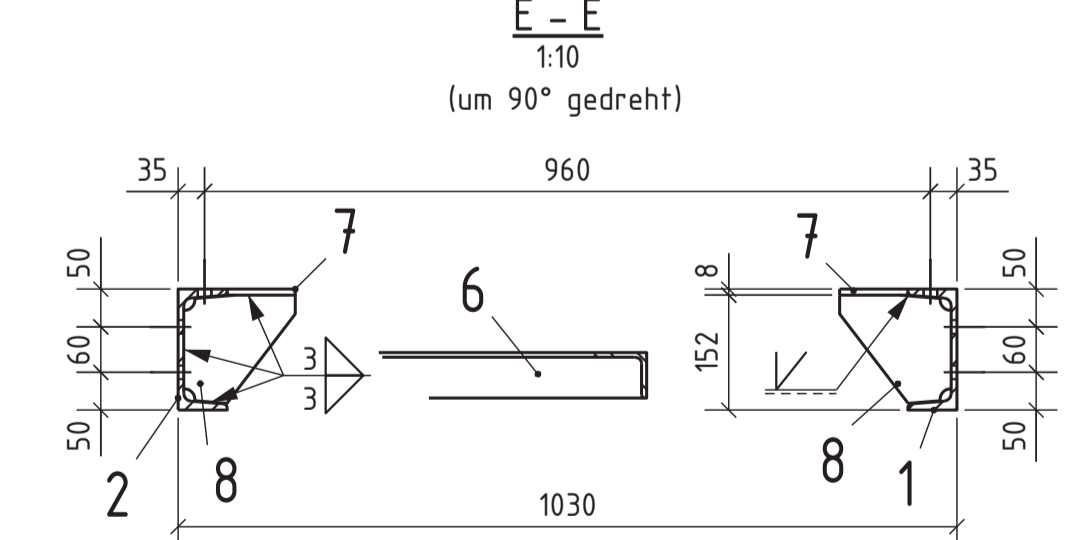
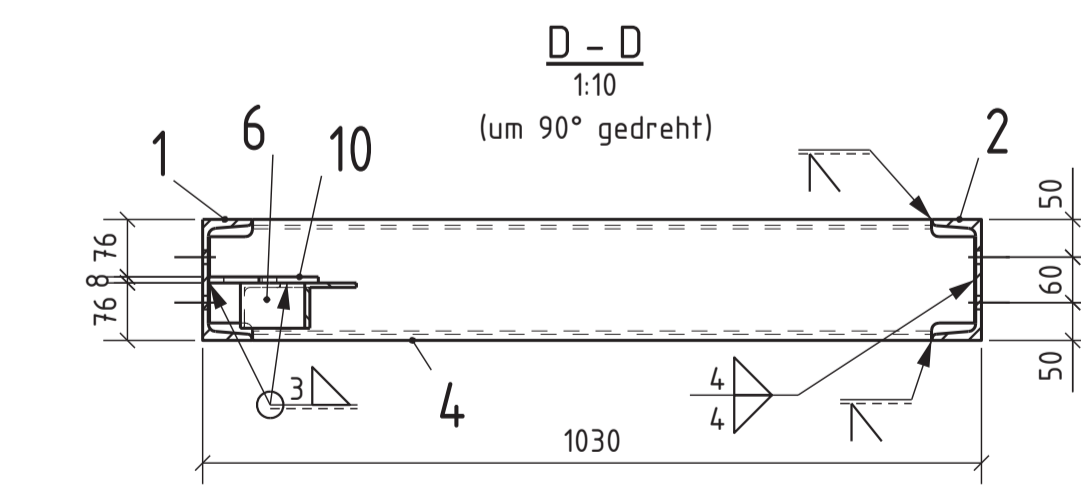
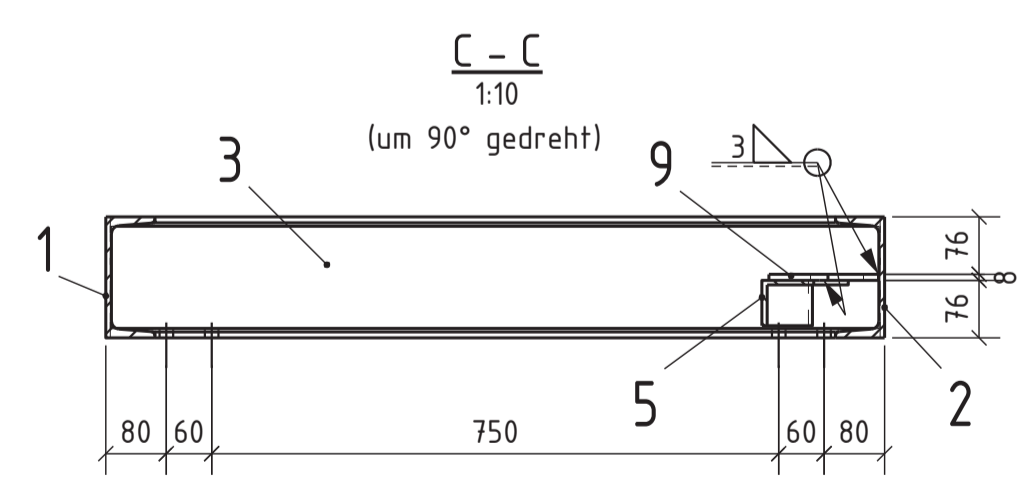
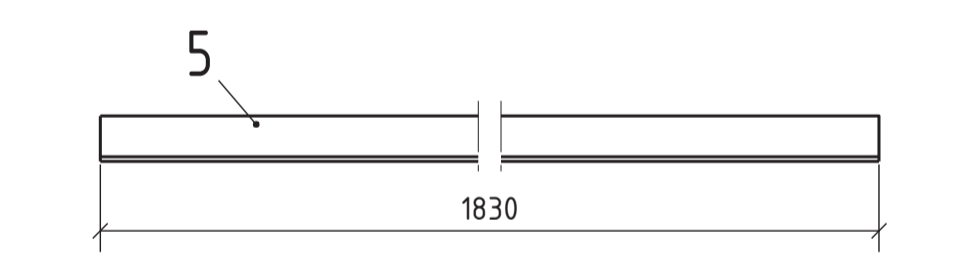
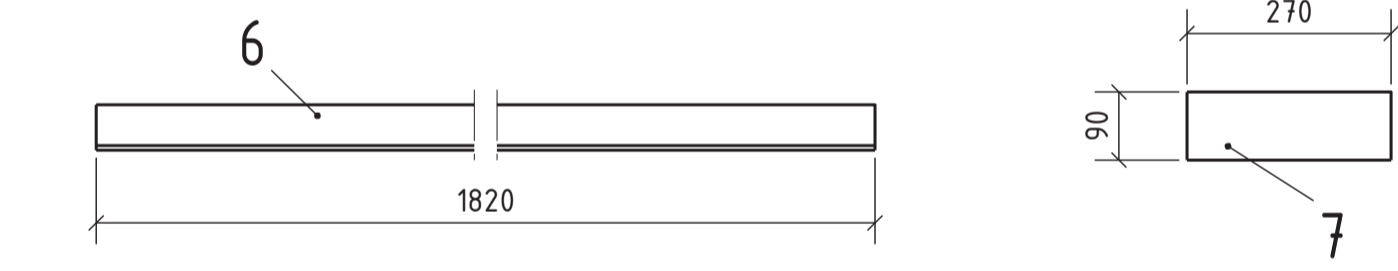
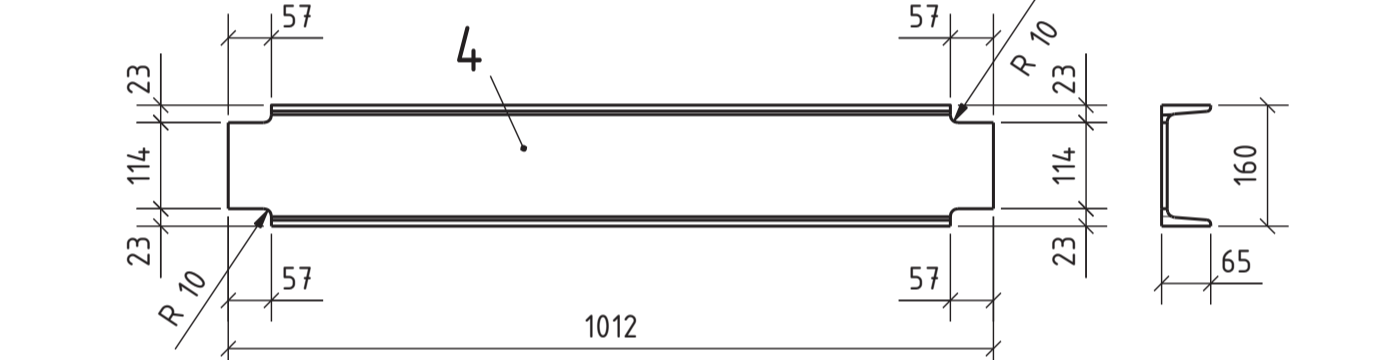
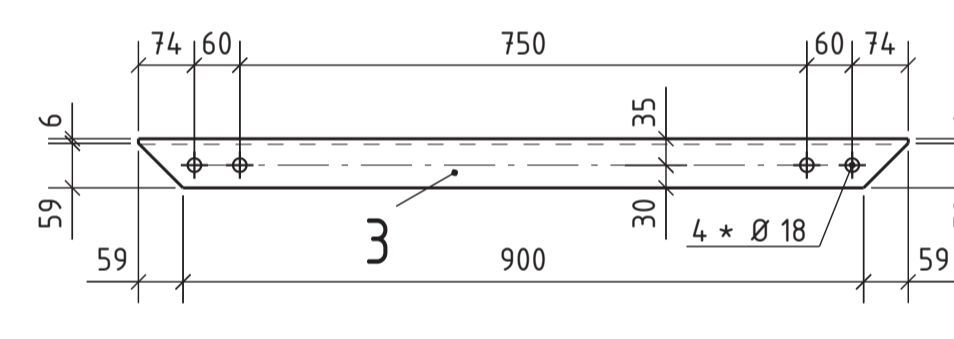
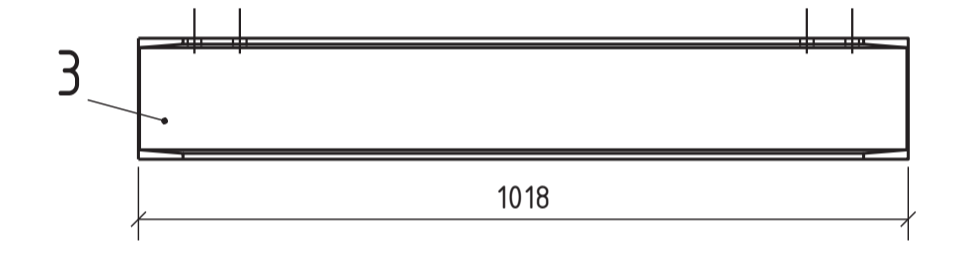
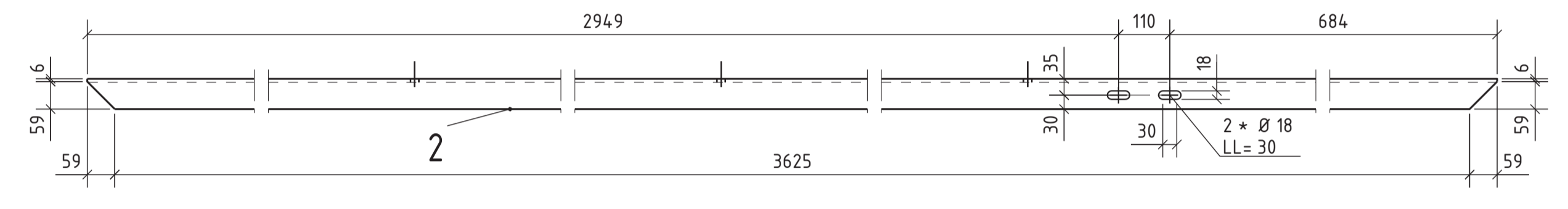
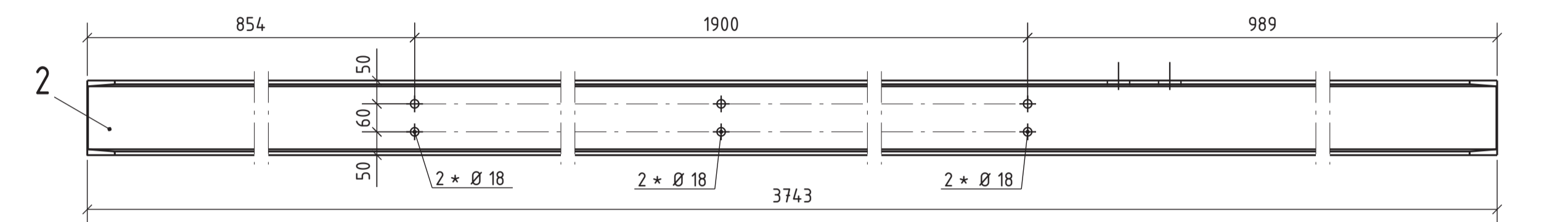
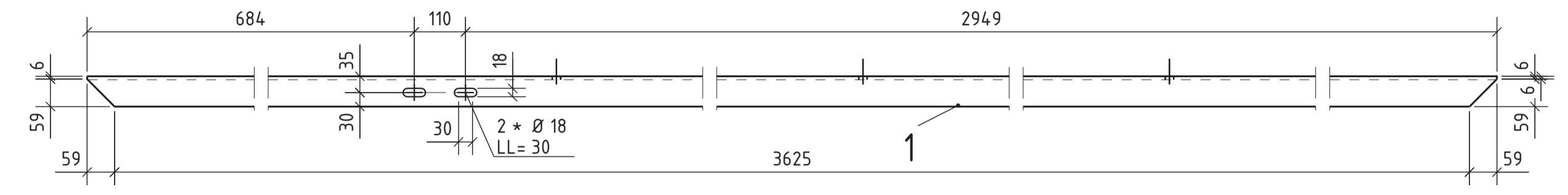
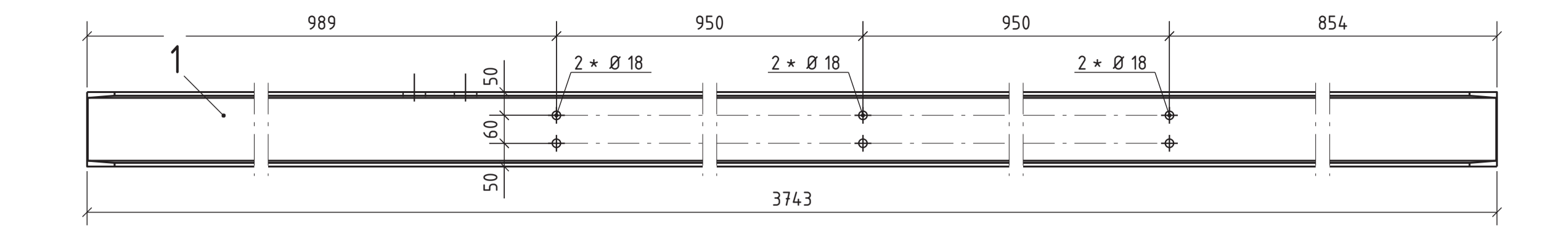
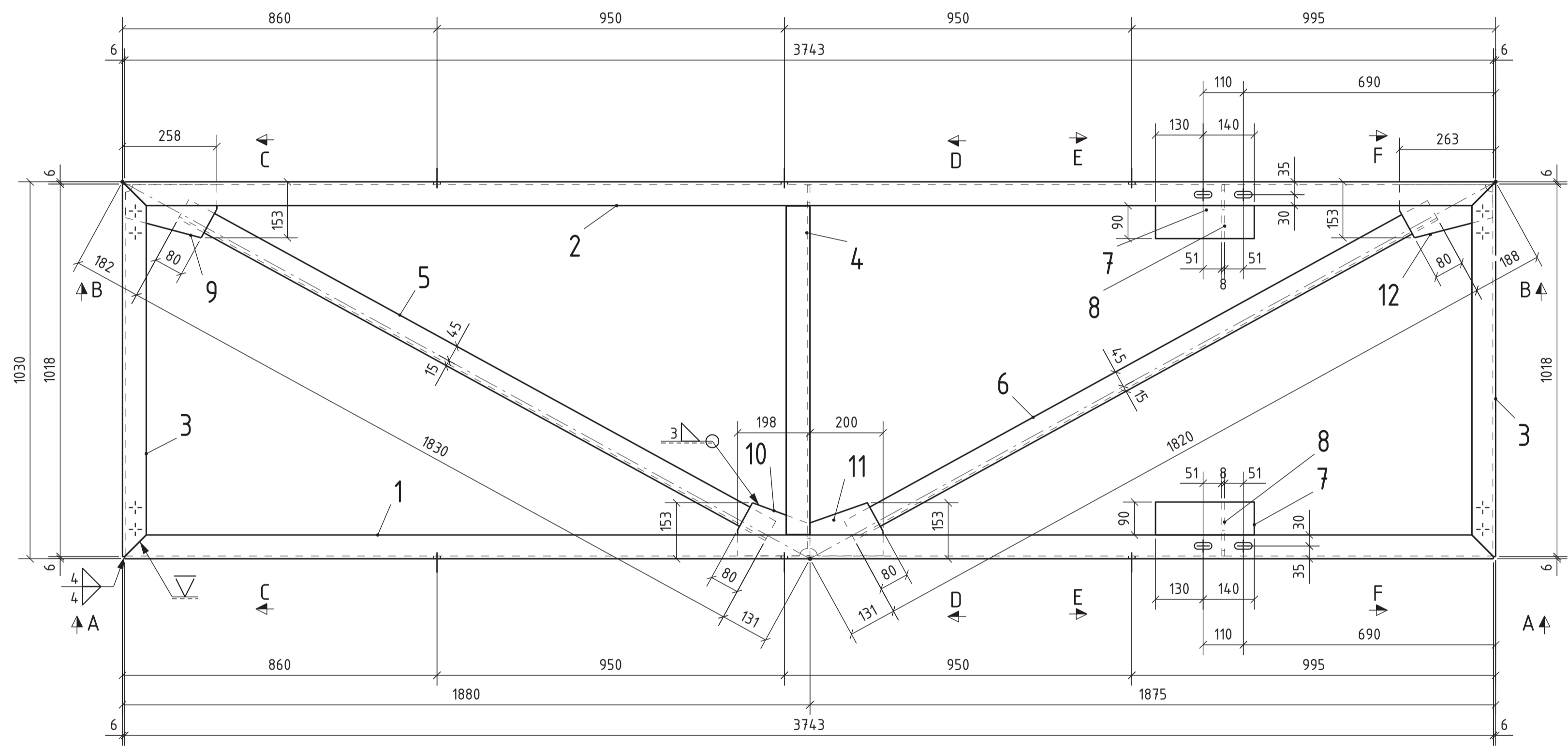

Stückliste 1x ausführen						Gesamtgewicht: 229.62 kg	
Stck.	Benennung	Norm	Werkstoff	Teil	Zusatzbezeichnung	Gewicht kg/Stck	Gewicht gesamt kg
1	BL8 x 145 x 255	EN 10029	S235JR	12	-	1.84	1.84
1	BL8 x 145 x 200	EN 10029	S235JR	11	-	1.42	1.42
1	BL8 x 145 x 190	EN 10029	S235JR	10	-	1.36	1.36
1	BL8 x 145 x 250	EN 10029	S235JR	9	-	1.79	1.79
2	BL8 x 14.7 x 14.3	EN 10029	S235JR	8	-	0.95	1.89
2	BL8 x 90 x 270	EN 10029	S235JR	7	-	1.53	3.05
1	L60*6 ... 1820	EN 10056	S235JR	6	-	9.87	9.87
1	L60*6 ... 1830	EN 10056	S235JR	5	-	9.93	9.93
1	U160 ... 1012	EN 1026	S235JR	4	-	19.07	19.07
2	U160 ... 1018	EN 1026	S235JR	3	-	19.18	38.36
1	U160 ... 374.3	EN 1026	S235JR	2	-	70.52	70.52
1	U160 ... 374.3	EN 1026	S235JR	1	-	70.52	70.52